



*Quality Products Since 1939*

Sliding & Folding Door  
Hardware

---

## About McCallum Australia

McCallum Australia has been manufacturing high quality hardware products for the Australian market since 1939.

Our products are designed and developed in Australia, made from the highest quality materials and processes to exceed the high demands of Australian Standards and the market.

McCallum Australia is the pre-eminent hinge manufacturer for Australia. Our products have been used in hundreds of thousands of projects across Australia – including some of the most prominent such as, The Sydney Opera House, New Parliament House Canberra, and Crown Casino.

McCallum's pioneered the extruded aluminium hinge that features aluminium pressed endcaps, keyed flanged nylon bearings and stainless-steel hinge pins. We have included these innovative design features in our popular heavy duty fast-fix hinge range.

Our range of products are used extensively throughout the Australian market and are sort after by tradespeople, specifiers and technicians for new projects, repairs, refurbishments, and retrofits.

McCallum Australia products are sought for their key attributes:

- Quality
- Reliability
- Technical innovation
- Value

We support this with a focus on strong customer support.

McCallum representatives and stockists would be pleased to discuss and offer advice regarding your hardware requirements.

For additional technical information please contact us

+61 2 9698 5111

[sales@mccallumhinges.com.au](mailto:sales@mccallumhinges.com.au)



---

## Contents

About McCallum Australia .....	1
VIO Top Hung Folding Door System.....	3
Bi-Folding Door Systems (internal) .....	5
Bi-Fold 14 Folding Door System 14kg.....	5
Bi-Fold 25 Folding Door System 25kg.....	6
Exposed Open Rail Track Systems .....	7
SD5014 Flat Rail Barn Door 100kg.....	7
SD5017 Round Bar Soft Close 80kg .....	8
Sliding Wardrobe Systems .....	9
SD5001 Sliding Robe Double 45kg.....	9
SD5002 Sliding Robe Double 30kg.....	10
SD5003 Sliding Robe Single 30kg.....	10

# VIO Top Hung Folding Door System

The VIO folding door hardware is suitable for residential and commercial timber or aluminium exterior folding door. Ideal for external applications being manufactured from corrosive resistant material - anodised aluminium track & guide channel, stainless steel hangers, hinges, and precision stainless steel bearing along with engineered polymer components.

Top hung end folding system suits door folding in one or both directions.

Two systems available suitable for doors to a maximum weight of either 50kg or 100kg per leaf.



## DOOR SPECIFICATION:

	<b>VIO-50</b>	<b>VIO-100</b>
Max door height:	3000mm	3300mm
Max door width:	1000mm	1000mm
Minimum Door thickness:	38mm	38mm
Max door weight:	50kg	100kg
Max No of doors:	8 each direction	8 each direction

## HARDWARE SPECIFICATION

### Tracks:

Material: VT50 – x length  
VT100 - x length  
Aluminium  
Finish: Clear Anodised Mill



VT50: Top Track



VT100: Top Track

### Guide Channel:

Material: VGC - x length  
Aluminium  
Finish: Clear Anodised Mill



VGC: Guide Channel

**Polypropylene Channel Insert:** VPCI - x length  
**Standard Lengths:** 2000, 3000, 4000 & 5000mm



VPCI: Poly Guide Channel Insert

### Pivot & Hanger Sets:

Pivot Set LH or RH VIO-1  
End Hanger set incl Guide LH or RH VIO-2  
Intermediate Hanger Set VIO-4  
Meeting Stile Hanger Set VIO-8

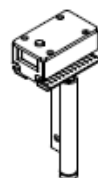

VIO-1



VIO-2

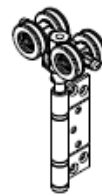

VIO-4

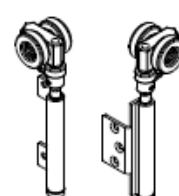

VIO-8

**Hinge Sets:**

Hinge Handle Set	VIO-3
Offset Hinge Handle Set	VIO-7
Hinge Set	VIO-5
Offset Hinge Set	VIO-6
Security Hinge	VIO-9

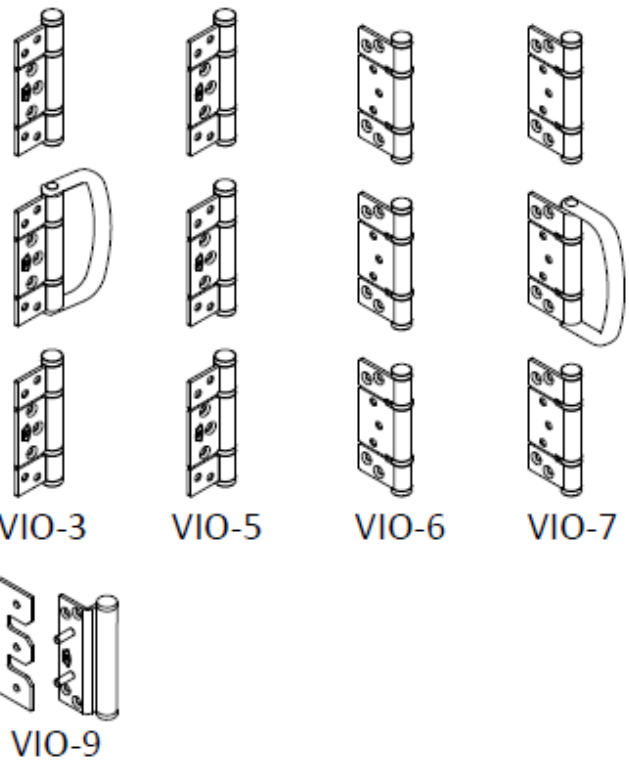

**Accessories:**

Flush Bolt Non-lockable	VFB
Flush Bolt Offset Non-lockable	VBFO
Flush Bolt Key Lockable	VFBL
Flush Bolt Offset Key lockable	VFBOL
Flush Bolts available lengths: 200, 400 & 600mm	

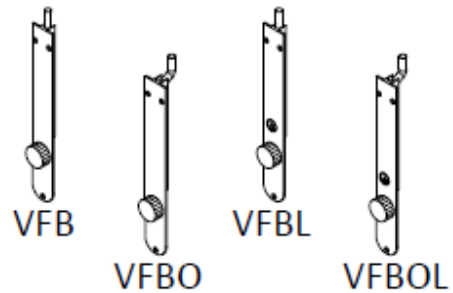

Magnetic Door Holder 25 x 30mm	DS101
Magnetic Door Holder 70 x 30mm	DS100

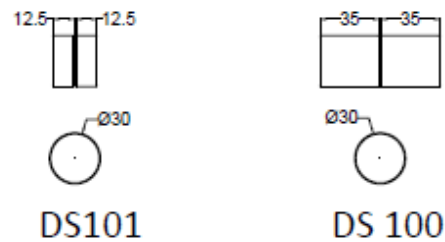

**Finishes:**

- SSS:** Satin Stainless Steel
- PSS:** Polished Stainless Steel
- BLK:** Black

## Bi-Folding Door Systems (internal)

The Bi-fold system is ideally suited for residential Wardrobe and Cupboard folding doors.

It is designed for use on timber doors in non-rebated timber frames.

Systems to suit doors up to a maximum weight of 25kg per leaf.

Standard 2 door and 4 door complete kits catering for openings up to 2460mm

Available as individual components for custom applications.



### Bi-Fold 14 Folding Door System 14kg

#### DOOR SPECIFICATION

Max door height:	2400mm
Max door width:	620mm
Door thickness:	16-35mm
Max door weight:	14kg

#### HARDWARE SPECIFICATION

Track:	BFD14-TR x length
Material:	Aluminium
Finish:	Clear Anodised Mill
Standard Lengths:	2000, 2500, 3000 & 4000mm
Pivot Set:	BFD14-PVT
Top Guide:	BFD14-TG
Door Aligner Set:	BFD14-DA
Hinge- Non-Mortice:	BFD3005-04

#### Standard Kits:

BF14-10/2: 2 Door Kit opening width up to 1000mm

BF14-12/2: 2 Door Kit opening width up to 1250mm

BF14-18/4: 4 Door (2+2) Kit opening width up to 1800mm

BF14-25/4: 4 Door (2+2) Kit opening width up to 2500mm

BF14-2D: 2 Door Fitting Kit (no Track)

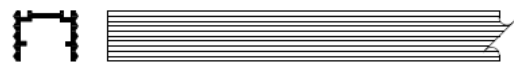
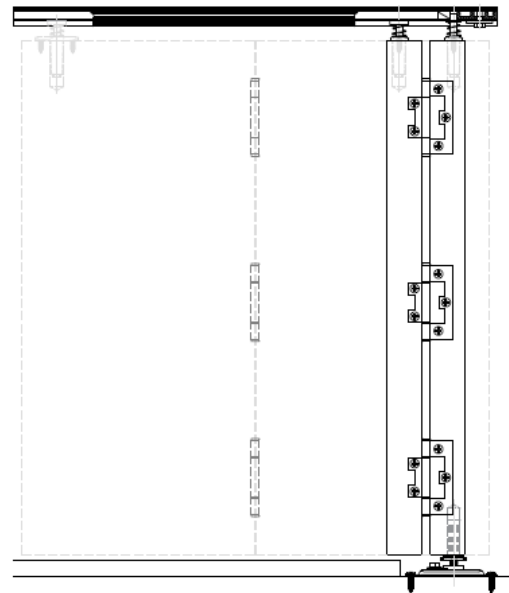

BFD14-TR: Aluminium Track



BFD14-PVT: Pivot Set



BFD14-TG: Top Guide

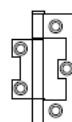

BFD-3005-04: Hinge Non-mortice

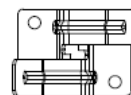

BFD14-DA: Door Aligner

## Bi-Fold 25 Folding Door System 25kg

### DOOR SPECIFICATION

Max door height:	2400mm
Max door width:	620mm
Door thickness:	19-45mm
Max door weight:	25kg

### HARDWARE SPECIFICATION

Track:	BFD25-TR x length
Guide Channel:	BFD25-GC x length
Material:	Aluminium
Finish:	Clear Anodised Mill
Standard Lengths:	2000, 2500, 3000 & 4000mm

Pivot Set:	BFD25-PVT
Four Wheel Hanger:	BFD25-HHG
Door Guide:	BFD25-DG
Bumper Track Stop:	BFD25-TS
Hinge- Non-Mortice:	BFD3005-04
Adjustment Spanner:	BFD5055-SP

### Standard Kits:

- BF25-12/2: 2 Door Kit opening width up to 1250mm
- BF25-25/4: 4 Door (2 +2) Kit opening width up to 2500mm
- BF25-2D: 2 Door Fitting kit

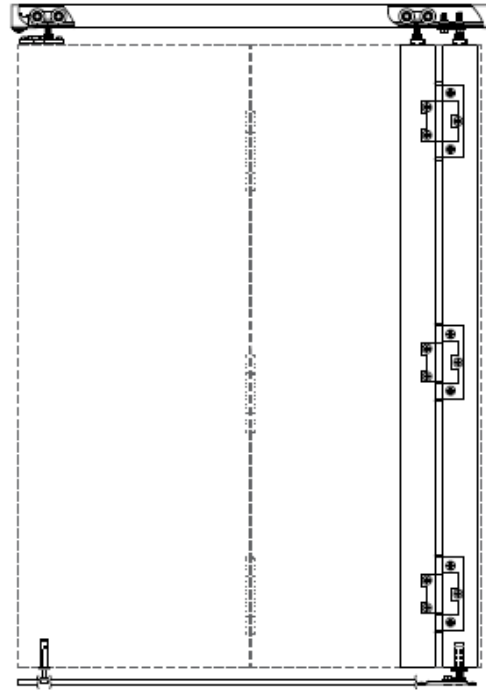

BFD25-TR: Aluminium Track

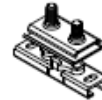

BFD25-T/PVT: Top Pivot



BFD25-B/PVT: Bottom Pivot

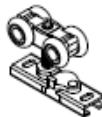

BFD25-HHG: Four Wheel Hanger



BFD25-TS: Bumper Track Stop

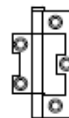

BFD-3005-04 Hinge Non-mortice



BFD25-DG: Door Guide



BFD25-GC: Guide Channel



BFD-5055SP: Adjustment Spanner



# Exposed Open Rail Track Systems

The exposed open rail sliding door systems are ideally suited for the commercial, industrial and or country style interiors. These sliding door systems come in either Flat Rail "Barn Door" and Round Bar with Strap or Top fix Hangers. The Hangers are constructed with Acetal Wheels, Stainless Steel precision bearing for smooth and quiet action. Suitable for doors up to a maximum weight of 100kg. Available in complete kits or as components for custom applications.



## SD5014 Flat Rail Barn Door 100kg

### DOOR SPECIFICATION

Max door height:	3000mm
Max door width:	1200mm
Door thickness:	35-45mm
Max door weight:	100kg

### HARDWARE SPECIFICATION

<b>Track:</b>	SD5014-TR x length
<b>Material:</b>	40x6mm Steel Flat Rail
<b>Finish:</b>	Black
<b>Standard Length:</b>	2000mm
<b>Wall Mount:</b>	SD5014-WS
<b>Hangers:</b>	SD5014-H
<b>Material:</b>	Steel Flat Strap Acetal wheels with Stainless Steel Precision Bearing
<b>Soft Close Kit:</b>	SD5014-SC
<b>Track Stop:</b>	SD5014-TS
<b>Material:</b>	Steel
<b>Floor Guide:</b>	SD5014-FG
<b>Material:</b>	Nylon

### Alternative Guide & Channel:

<b>Floor Guide:</b>	SD4046
<b>Guide Channel:</b>	SD-U43

### Standard Kit:

SD5014-20BLK: Flat Rail Barn Door kit BLK 2000mm

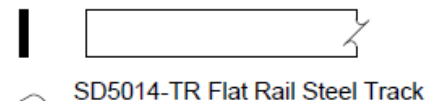
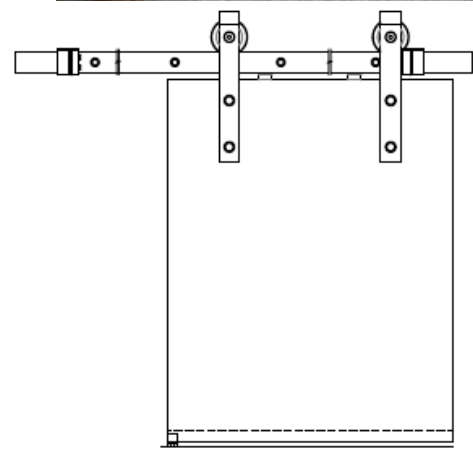

SD5014-TR Flat Rail Steel Track



SD5014-H: Flat Strap Hanger



SD5014-TS: Track Stop



SD5014-WS: Wall Mount Spacer



SD5014-FG: Floor Guide

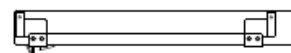

SD5014-SC: Soft Close Kit



SD4046: Floor Guide

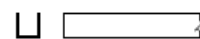

SD-U43: Guide Channel



## SD5017 Round Bar Soft Close 80kg

### DOOR SPECIFICATION

Max door height:	3000mm
Max door width:	1200mm
Door thickness:	35-45mm
Max door weight:	80kg

### HARDWARE SPECIFICATION

<b>Track:</b>	SD5011-TR x length
<b>Material:</b>	Ø25mm Stainless Steel 304 grade
<b>Finish:</b>	Satin Stainless Steel
<b>Standard Length:</b>	2000mm
<b>Wall Mount:</b>	SD5012-WS
<b>Hangers:</b>	SD5012-H
<b>Material:</b>	Stainless Steel 304 grade Stainless Steel with Acetal inserted wheels
<b>Track Stop:</b>	SD5016-TS
<b>Material:</b>	Stainless Steel 304 grade
<b>Soft Close/Open</b>	SD5017-SC
<b>Floor Guide:</b>	SD5012-FG
<b>Material:</b>	Stainless Steel 304 grade & POM (Acetal) Guide

### Alternative Guide & Channel:

Floor Guide:	SD4046
Guide Channel:	SD-U43

### Standard Kit:

SD5017-20SSS: Round Bar Soft Close kit 80kg 2000mm

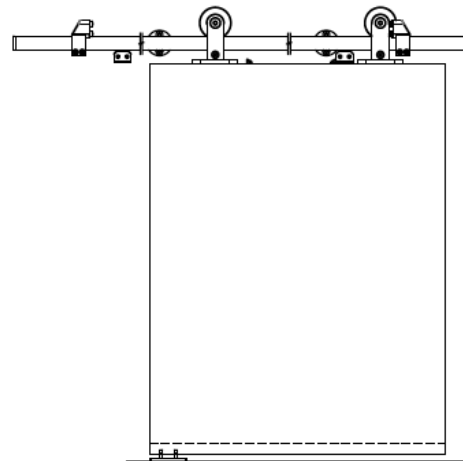

SD5011-TR: Track Ø25mm Round Bar



SD5016-H: Top Mount Hanger



SD5016-TS: Track Stop



SD5012-WS: Wall Mount Spacer



SD5012-FG: Floor Guide

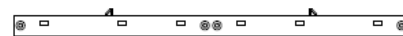

SD5017-SC: Soft Close



SD4046: Floor Guide

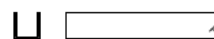

SD-U43: Guide Channel

# Sliding Wardrobe Systems

The residential Wardrobe Double system is ideally suited for 2 or 3 Wardrobe and Cupboard doors.

Aluminium top track with a durable clear anodised finish.  
Adjustable face fix Hangers with precision bearing nylon rollers for smooth quiet action.

Systems to suit doors up to a maximum weight of 45kg per leaf.

Available in complete kits or as components for custom applications.



## SD5001 Sliding Robe Double 45kg

### DOOR SPECIFICATION

Max door height:	2400mm
Max door width:	900mm
Door thickness:	16-40mm
Max door weight:	45kg

### HARDWARE SPECIFICATION

<b>Track:</b>	SD5001-TR x length
<b>Guide Channel:</b>	SD5001-GC x Length
<b>Material:</b>	Aluminium
<b>Finish:</b>	Clear Anodised Mill
<b>Standard Lengths:</b>	2000, 3000 & 4000mm
<b>Hangers:</b>	SD5001-H1 Offset In SD5001-H2 Offset Out
<b>Material:</b>	Pressed Steel & Nylon Rollers
<b>Door Stop:</b>	SD5001-DS
<b>Material:</b>	Nylon
<b>Door Guide:</b>	SD5001-DG
<b>Material:</b>	Nylon

### Standard Kits:

SD5001-12/2:	2 Door Kit Opening 1200mm
SD5001-15/2:	2 Door Kit Opening 1500mm
SD5001-18/2:	2 Door Kit Opening 1800mm
SD5001-24/3:	3 Door Kit Opening 2400mm

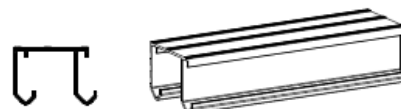
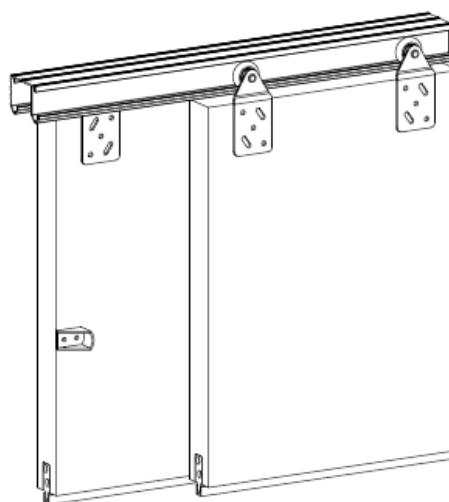

SD5001-TR: Aluminium Track

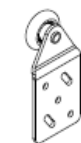

SD5001-H1: Hanger Offset In



SD5001-H2: Hanger Offset Out



SD5001-DS: Door Stop



SD5001-DG: Door Guide



SD5001-GC: Guide Channel

## SD5002 Sliding Robe Double 30kg

### DOOR SPECIFICATION

Max door height:	2400mm
Max door width:	900mm
Door thickness:	16-35mm
Max door weight:	30kg

### HARDWARE SPECIFICATION

<b>Track:</b>	SD5002-TR x length
Material:	Aluminium
Finish:	Clear Anodised Mill
Standard Lengths:	2000, 3000 & 4000mm
<b>Hangers:</b>	SD5002-H1 Offset Out SD5002-H2 Offset In
Material:	Pressed Steel & Nylon Rollers
<b>Door Stop:</b>	SD5001-DS
Material:	Nylon
<b>Floor Guide:</b>	SD5002-FG
Material:	Nylon

### Standard Kits:

SD5002-12/2:	2 Door Kit Opening 1200mm
SD5002-15/2:	2 Door Kit Opening 1500mm
SD5002-18/2:	2 Door Kit Opening 1800mm
SD5002-24/3:	3 Door Kit Opening 2400mm

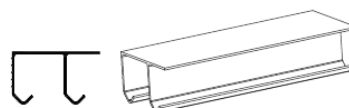
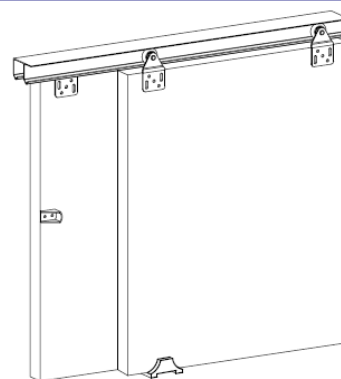

SD5002-TR: Aluminium Track



SD5002-H1: Hanger Offset Out



SD5002-H2: Hanger Offset In



SD5001-DS: Door Stop

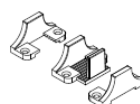

SD5002-FG: Floor Guide

## SD5003 Sliding Robe Single 30kg

### DOOR SPECIFICATION

Max door height:	2400mm
Max door width:	900mm
Door thickness:	16-35mm
Max door weight:	30kg

### HARDWARE SPECIFICATION

<b>Track:</b>	SD5003-TR x length
Material:	Aluminium
Finish:	Clear Anodised Mill
Standard Lengths:	2000, 3000 & 4000mm
<b>Hangers:</b>	SD5002-H2 Offset In
Material:	Pressed Steel & Nylon Rollers
<b>Door Stop:</b>	SD5001-DS
Material:	Nylon
<b>Floor Guide:</b>	SD5003-FG
Material:	Nylon

### Standard Kits:

SD5003-12/1:	Single Robe Door Kit Opening 1200mm
SD5003-15/1:	Single Robe Door Kit Opening 1500mm
SD5003-18/1:	Single Robe Door Kit Opening 1800mm
SD5003-DR:	Single Door Fitting Kit (No Track)

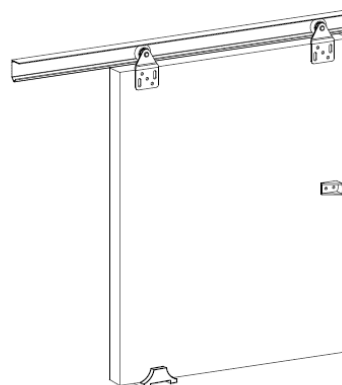

SD5003-TR: Aluminium Track



SD5002-H2: Hanger Offset In



SD5001-DS: Door Stop



SD5003-FG: Floor Guide